

(No Model.)

A. CHATWIN.
Lathe Chuck.

No. 239,444.

Patented March 29, 1881.

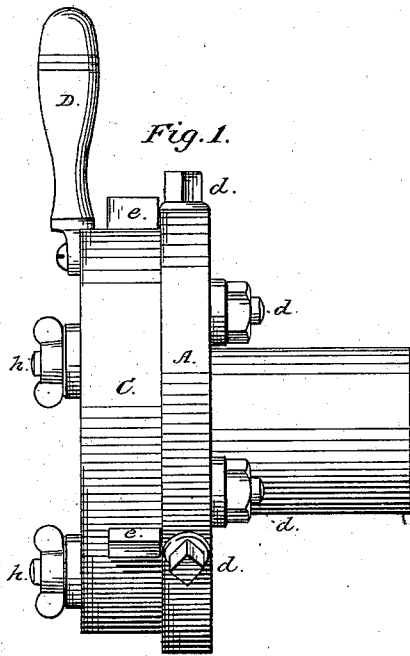

Fig. 1.

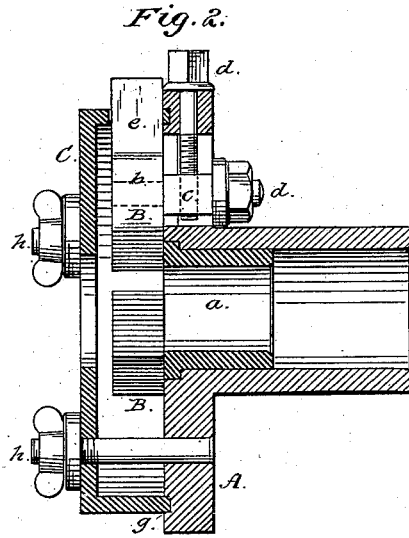

Fig. 2.

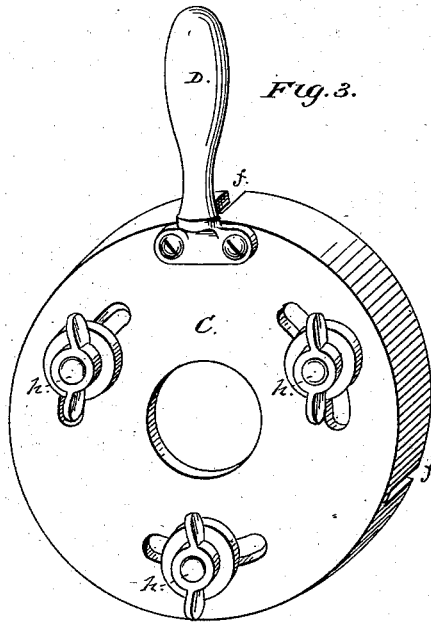

Fig. 3.

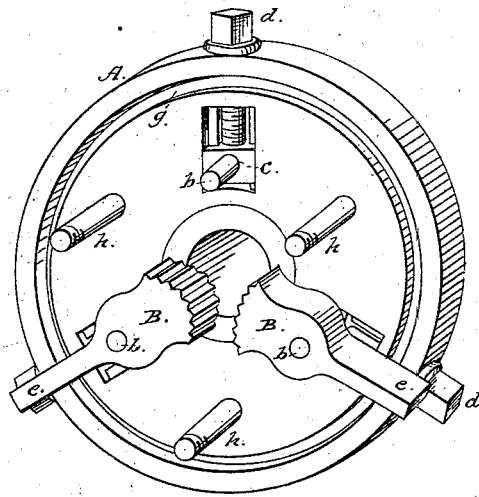

Fig. 4.

Attest:

H. W. Howard
F. H. Sawyer.

Inventor,
Ambrose Chatwin
by
Geo. A. Sawyer.
Attorney.

UNITED STATES PATENT OFFICE.

AMBROSE CHATWIN, OF BROOKLYN, NEW YORK, ASSIGNOR TO ROBERT MITCHELL, OF MONTREAL, CANADA.

LATHE-CHUCK.

SPECIFICATION forming part of Letters Patent No. 239,444, dated March 29, 1881.

Application filed September 28, 1880. (No model.)

To all whom it may concern:

Be it known that I, AMBROSE CHATWIN, of the city of Brooklyn, in the State of New York, but at present residing temporarily in the city and district of Montreal, in the Province of Quebec, Dominion of Canada, have invented certain new and useful Improvements in Internal Gripping-Chucks, of which the following is a specification.

10 The object of the invention is to facilitate the operation of cutting screw-threads on tubes or bolts; and the invention will be understood as set forth in the following description and claims.

15 In the accompanying drawings, Figure 1 is an external side elevation, Fig. 2 is a vertical section, Fig. 3 is a perspective view, of the outer covering-plate. Fig. 4 is a perspective view of the chuck with the covering-plate removed.

20 Similar letters of reference indicate like parts in all the figures.

A is the face-plate, adapted for insertion into a screw-cutting machine in the usual way. 25 *a* is a metal ferrule or lining to receive the tube or bolt to be threaded.

30 B B are the toothed cams, pivoted at *b b* to the face-plate A, either directly or through the intervention of adjusting and retaining screws *d d*, for adapting the cams to any required size of tube or bolt. The cams B are formed with shanks or blades *e* at their outer ends, passing through the slots *f f f* in the periphery of the hollow cylindrical plate C, which is adapted 35 to cover and protect the cams, and at the same time to slide in an annular groove, *g*, in the face-plate A, thereby giving motion to the

cams on their pivots or axes *b*. In order to regulate this motion, and to keep the covering-plate C pressed against the face-plate A with 40 just sufficient friction to steady the working parts, three thumb-screws, *h h h*, are introduced and may be tightened or loosened, as required.

The hand-lever D may be turned so as to 45 bring the cams B to bear upon the tube or bolt, the plate C moving around the plate A in the groove *g*.

The operation of the device is as follows: The cams B being adjusted to suit the size of 50 the tube or bolt to be threaded by means of the screws *d*, and the covering-plate C being in place, with the blades *e* projecting through the slot *f*, the lever D is turned until the corrugated faces of the cams B have a proper 55 gripe on the tube or bolt and the thread can be cut.

Having thus described my invention, I desire to claim—

1. The herein-described gripping-chuck, having 60 the plate A, cams B, mounted on adjustable pins *b d*, in combination with the covering-plate C, substantially as set forth.

2. The combination of the plate A, provided with the adjustable pins *b d* and the stationary pins *h*, with the cams B, having blades *e*, 65 and with the covering-plate C, having slots *f*, and lever D, all constructed and arranged substantially as set forth.

AMBROSE CHATWIN.

Witnesses:

R. HENNESSY,
W. A. PHILLIPS.